

CrystaLatch™ 1x2 High Power (> 10W) Series Fiber Optic Switch

(SM, PM, Unidirectional, Bidirectional, High Power)

(Protected by U.S. patents 7224860, 6757101, 6577430 and pending patents)



DATASHEET

[Return to the Webpage](#)



The CL 1x2 High Power (>10W) series Switch connects optical channels by redirecting an incoming optical signal into a selected output fiber. This is achieved using patented non-mechanical configurations and activated via an electrical control signal. Latching operation preserves the selected optical path after the drive signal has been removed. The all High Power fiberoptic switch features low insertion loss, high extinction ratio, high channel isolation, and extremely high reliability and repeatability. It is designed to meet the most demanding switching requirements of continuous operation without failure, longevity, operation under shock/vibration environment, and large temperature variations, and fast response time.

The switch also has build-in Circulator and isolator functions. Electronic driver is available for this series of switches.

The magneto-optical crystals used in the CL switches have no fatigue nor drift effect.

Features

- Solid-State high speed
- High power
- Ultra-high reliability
- Fail-safe latching
- Low insertion loss
- Direct low voltage drive
- Compact
- Low cost

Applications

- Optical channel blocking
- Configurable Add/Drop
- System monitoring
- Instrumentation

Specifications

Parameter	Min	Typical	Max	Unit
Operation Wavelength ^[1]	1520	1550	1580	nm
	1295	1310	1325	nm
Insertion Loss ^[2]	Single stage	0.6	0.9	dB
	Dual Stage	0.8	1.1	dB
Cross Talk ^[2]	Single stage	18	25	dB
	Dual Stage	36	50	dB
Polarization Dependent Loss ^[2] (SM)		0.1	0.2	dB
Extinction Ratio ^[2] (PM)	18			dB
Return Loss ^[2]	50	55		dB
Polarization Mode Dispersion		0.1	0.2	ps
Optical Switching Speed (Rise, Fall)		50	200	μs
Repetition Rate		2K		Hz
Durability	10 ¹⁵			cycle
Optical Power Handling	> 10 ^[4]			W
Operating Temperature ^[3]	-5		70	°C
Storage Temperature	-40		85	°C
Fiber Type	SM	Corning SMF-28, or equivalent		
	PM	Panda PM 250, or equivalent		

Notes:

- [1]. Agiltron can achieve same SPEC at L band.
- [2]. Measured without connectors.
- [3]. -40°C version is also available, please call us.
- [4]. Continuous operation, for pulse operation call.

Legal notices: All product information is believed to be accurate and is subject to change without notice. Information contained herein shall legally bind Agiltron only if it is specifically incorporated into the terms and conditions of a sales agreement. Some specific combinations of options may not be available. The user assumes all risks and liability whatsoever in connection with the use of a product or its application.

Rev 10/14/25

© Photonwares Corporation

P +1 781-935-1200

E sales@photonwares.com

W www.agiltron.com

Information contained herein is deemed to be reliable and accurate as of the issue date. Photonwares reserves the right to change the design or specifications at any time without notice. Agiltron is a registered trademark of Photonwares Corporation in the U.S. and other countries.

CrystaLatch™ 1x2 High Power (> 10W) Series Fiber Optic Switch



(SM, PM, Unidirectional, Bidirectional, High Power)

(Protected by U.S. patents 7224860, 6757101, 6577430 and pending patents)

DATASHEET

Mechanical Dimensions (Unit: mm)

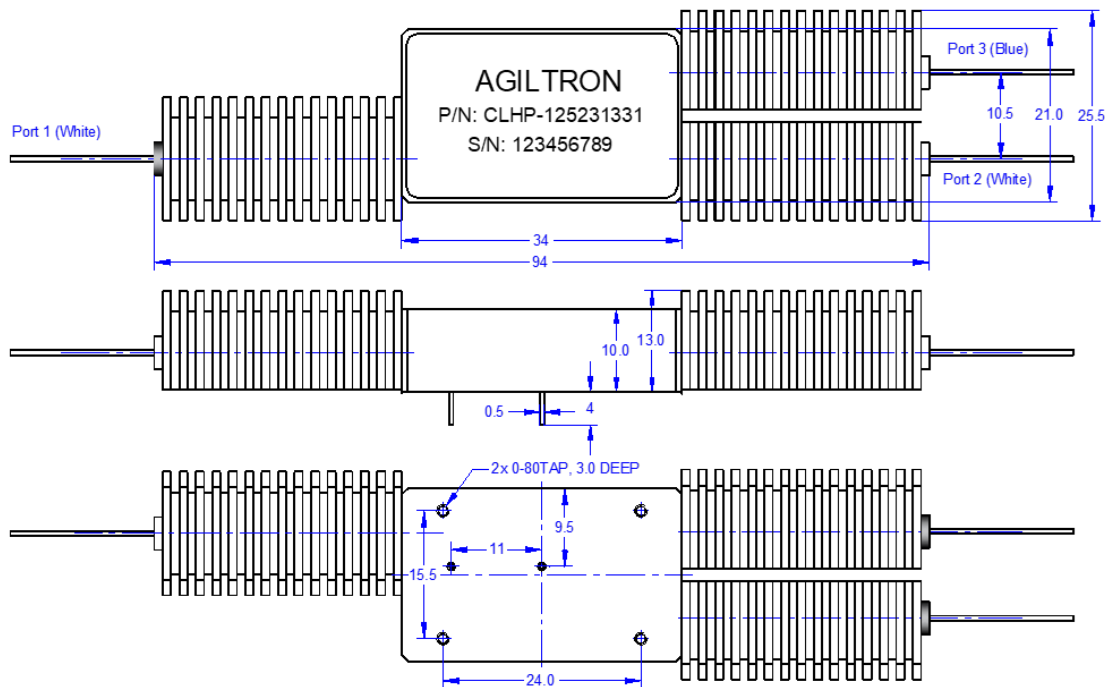

*Product dimensions may change without notice. This is sometimes required for non-standard specifications.

Function Diagram

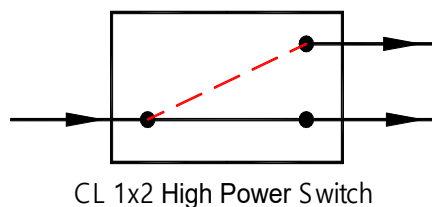

Electrical Driving Information

The switch is actuated by applying a voltage pulse. Applying one polarity pulse, one light path will be connected and latched to the position. Applying a reversed polarity pulse, another light path will be connected and latched to the position after pulse removed.

Parameter		Minimum	Typical	Maximum	Unit
Drive Voltage	Single Stage	2.25	2.5	2.75 ^[1]	V
	Dual Stage	4.5	5	5.5 ^[1]	V
Drive Current (each Coil)		110	140	195	mA
Pulse Duration		0.2	0.3	0.5	ms

[1]. Over this value will damage the device

Driving kit with USB and RS232, or RS232, or TTL interfaces is available. We provide GUI for USB and RS232 interface. Please contact Agiltron sales.

CrystaLatch™ 1x2 High Power (> 10W) Series Fiber Optic Switch



(SM, PM, Unidirectional, Bidirectional, High Power)

(Protected by U.S. patents 7224860, 6757101, 6577430 and pending patents)

DATASHEET

Single Stage Driving table

1). Bidirectional series 1x2 or 2x1 Switch

Optical Path	Pin 1	Pin 2
Port 1 ↔ Port 2	0	2.5V Pulse
Port 1 ↔ Port 3	2.5V Pulse	0

2). Unidirectional series 1x2 Switch

Optical Path	Pin 1	Pin 2
Port 1 → Port 2	0	2.5V Pulse
Port 1 → Port 3	2.5V Pulse	0

3). Unidirectional series 2x1 Switch

Optical Path	Pin 1	Pin 2
Port 2 → Port 1	2.5V Pulse	0
Port 3 → Port 1	0	2.5V Pulse

Dual Stage Driving table

1). Bidirectional series 1x2 or 2x1 Switch

Optical Path	Pin 1	Pin 2
Port 1 ↔ Port 2	0	5V Pulse
Port 1 ↔ Port 3	5V Pulse	0

2). Unidirectional series 1x2 Switch

Optical Path	Pin 1	Pin 2
Port 1 → Port 2	0	5V Pulse
Port 1 → Port 3	5V Pulse	0

3). Unidirectional series 2x1 Switch Driving Table

Optical Path	Pin 1	Pin 2
Port 2 → Port 1	5V Pulse	0
Port 3 → Port 1	0	5V Pulse

Note:

The driving voltage value is transient voltage with a full load. The driver circuitry needs to provide sufficient current (~300mA) during the switching. Inside the switch core is an electromagnet with a residual magnetic field. The residual magnetic field will be established when an electrical current flows in one direction through the coil for a sufficiently long period. The residual magnetic field latches the switch state even without applying a voltage (the current flow stopped). Flowing a current in the opposite direction for a sufficient time changes the switch stage by establishing a reversal magnetic field. The coil is forgiving to the driver unless one burns it by applying a higher voltage or a current for too long (day). The switch can also be operated at high repetition rates of kHz, where the residual magnetic field may not be fully established.

Ordering Information (Part Number)

Prefix	Type	Wavelength	Switch	Package	Fiber Type	Fiber Cover	Fiber Length	Connector ^{[5][6]}
CLHP- ^[1]	1x1 = 11	1310 = 3	Single Stage = 1	> 10W = H	SMF-28 = 1	Bare fiber = 1	0.25m = 1	None = 1
CLPH- ^[2]	1x2 = 12	1550 = 5	Dual Stage = 2	Special = 0	PM 1550 = B	900 μm tube = 3	0.5m = 2	Special = 0
CLHB- ^[3]	2x1 = 21	Special = 0	Special = 0		PM 1310 = D	Special = 0	1.0m = 3	
CPHB- ^[4]	Special = 00				Special = 0		Special = 0	

[1]. **CLHP**: CrystaLatch SM High Power Switch.

[2]. **CLPH**: CrystaLatch PM High Power Switch.

[3]. **CLHB**: CrystaLatch SM High Power Bidirectional Switch.

[4]. **CPHB**: CrystaLatch PM High Power Bidirectional Switch.

[5]. There isn't any connector in high power switches. Please contact us for high power connectors.

Regular fiber connector has PER ~22dB. Connector with PER >27 dB is available using special process

[6]. The connector cannot be installed directly onto bare fiber, as it is prone to damage during shipping. However, the connector can be assembled on bare fiber if a 3 cm protective loose tube is added for reinforcement. The customer can remove this protective tube after testing. The optical power handling of a standard connector is less than 0.5 W for SM28 fiber and decreases further with smaller core fibers.

CrystaLatch™ 1x2 High Power (> 10W) Series Fiber Optic Switch



(SM, PM, Unidirectional, Bidirectional, High Power)

(Protected by U.S. patents 7224860, 6757101, 6577430 and pending patents)

DATASHEET

Typical Switching Response

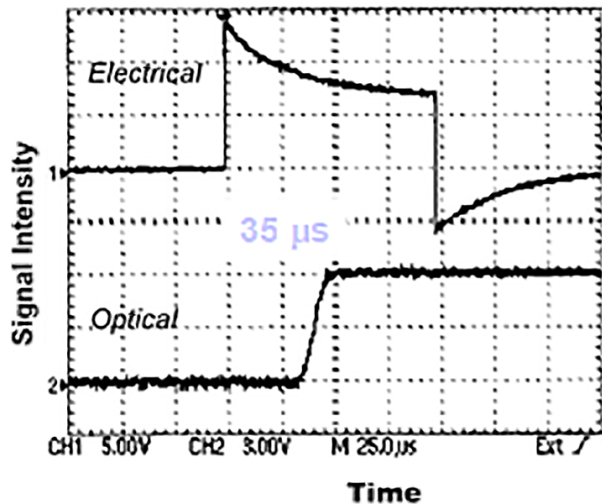

Typical Loss Change of 1x2 vs Switching Numbers

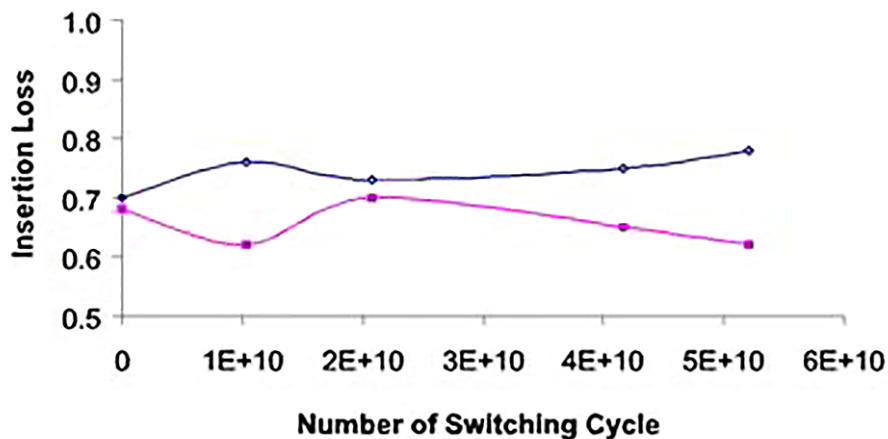

Fiber Core Alignment

Note that the minimum attenuation for these devices depends on excellent core-to-core alignment when the connectors are mated. This is crucial for shorter wavelengths with smaller fiber core diameters that can increase the loss of many decibels above the specification if they are not perfectly aligned. Different vendors' connectors may not mate well with each other, especially for angled APC.

Fiber Cleanliness

Fibers with smaller core diameters (<5 μm) must be kept extremely clean, contamination at fiber-fiber interfaces, combined with the high optical power density, can lead to significant optical damage. This type of damage usually requires re-polishing or replacement of the connector.

Maximum Optical Input Power

Due to their small fiber core diameters for short wavelength and high photon energies, the damage thresholds for device is substantially reduced than the common 1550nm fiber. To avoid damage to the exposed fiber end faces and internal components, the optical input power should never exceed 20 mW for wavelengths shorter 650nm. We produce a special version to increase the how handling by expanding the core side at the fiber ends.

CrystaLatch™ 1x2 High Power (> 10W) Series Fiber Optic Switch



(SM, PM, Unidirectional, Bidirectional, High Power)

(Protected by U.S. patents 7224860, 6757101, 6577430 and pending patents)

DATASHEET

Driver Design Example for 1x4

A recommended +5VDC powered driving circuit is provided. The resistor network R1~R8 is to suppress the driving signal's voltage level to meet the "switch voltage" requirements. In specific applications, users can use lower voltage to eliminate the R1~R8. The Q1~Q8 is the control signal from either a function generator or a microcontroller general purpose I/O. The Q1~Q8 switching speed must meet the specific MOSFET switching requirement and CL 1x4 Switch specific requirement. Usually, the control signal speed is $\leq 2\text{kHz}$.

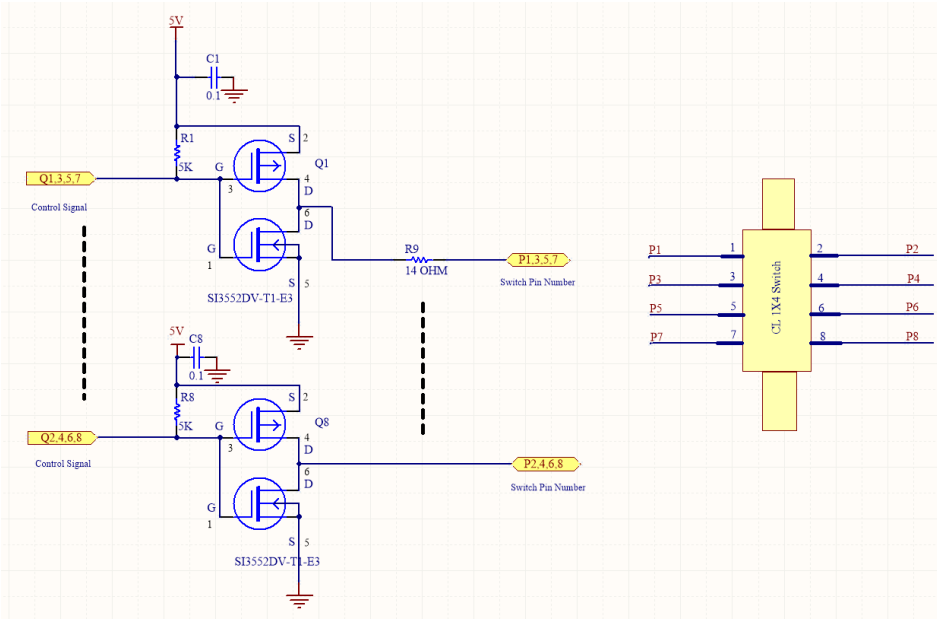

Usually, a clean power supply source will be sufficient. However, decoupling capacitors for the transistor supply rail are recommended depending on different applications. Minimum the current loop on the switching circuits will minimize the switching noise. For other layout recommendations, please refer to books or application notes from the IC manufacturer.